

Operating Instructions
Read and observe these Operating Instructions!

Laboport[®] Mini Laboratory Pumps

N938.50 KN.18

N938.50 KT.18



KNF Neuberger GmbH
Alter Weg 3
D-79112 Freiburg
Germany
Phone +49-(0)7664 / 5909-0
Fax +49-(0)7664 / 5909-99
E-Mail: info@knf.de
www.knf.de

Contents

	Page
1. About this document.....	3
2. Use	4
3. Safety	5
4. Technical Data	7
5. Design and Function	10
6. Installation and connection.....	11
7. Operation.....	12
8. Servicing.....	14
9. Troubleshooting.....	18
10. Spare parts and accessories.....	20
11. Returns.....	21
12. Health and safety clearance and decontamination form.....	22

1. About this document

1.1. Using the Operating Instructions

The Operating Instructions are part of the pump.

- Carefully study the Operating Instructions before using a pump.
- Always keep the Operating Instructions handy in the work area.
- Pass on the Operating Instructions to the next owner.

Project pumps

Customer-specific project pumps (pump models which begin with “PJ” or “PM”) may differ from the Operating Instructions.

- For project pumps, also observe the agreed upon specifications.

1.2. Symbols and Markings

Warning



WARNING

A danger warning is located here.

Possible consequences of a failure to observe the warning are specified here. The signal word, e.g. Warning, indicates the danger level.

- Measures for avoiding the danger and its consequences are specified here.

Danger levels

Signal word	Meaning	Consequences if not observed
DANGER	warns of immediate danger	Death or serious injuries and/or serious damage are the consequence.
WARNING	warns of possible danger	Death or serious injuries and/or serious damage are possible.
CAUTION	warns of a possibly dangerous situation	Minor injuries or damage are possible.

Tab. 1

Other information and symbols

- An activity to be carried out (a step) is specified here.
- 1. The first step of an activity to be carried out is specified here. Additional, consecutively numbered steps follow.

i This symbol refers to important information.

2. Use

2.1. Proper use

The pumps are exclusively intended for transferring gases and vapors.

Owner's responsibility

Operating parameters and conditions	<p>Only install and operate the pumps under the operating parameters and conditions described in chapter 4, Technical data.</p> <p>Make sure that the installation location is dry and the pump is protected against rain, splash, hose and drip water.</p>
Requirements for transferred medium	<p>Before using a medium, check whether the medium can be transferred danger-free in the specific application case.</p> <p>Before using a medium, check the compatibility of the materials of the pump head, diaphragm and valves with the medium.</p> <p>Only transfer gases which remain stable under the pressures and temperatures occurring in the pump.</p>
Accessories	<p>Laboratory equipment or additional components connected to a pump have to be suitable for use with the pneumatic capabilities of the pump.</p>

2.2. Improper use

The pumps may not be operated in an explosive atmosphere.

The pumps are not suitable for transferring dusts.

The pumps are not suitable for transferring liquids.

The pumps must not be used to create vacuum and overpressure simultaneously.

An overpressure must not be applied to the suction side of the pump.

3. Safety

i Note the safety precautions in chapters 6. *Installation and connection*, and 7. *Operation*.

The pumps are built according to the generally recognized rules of technology and in accordance with the occupational safety and accident prevention regulations. Nevertheless, dangers can result during their use which lead to injuries to the user or others, or to damage to the pump or other property.

Only use the pumps when they are in a good technical and proper working order, in accordance with their intended use, observing the safety advice within the operating instructions, at all times.

Personnel

Make sure that only trained and instructed personnel or specially trained personnel work on the pumps. This especially applies to assembly, connection and servicing work.

Make sure that the personnel has read and understood the operating instructions, and in particular the "Safety" chapter.

Working in a safety-conscious manner

Observe the accident prevention and safety regulations when performing any work on the pump and during operation.

Do not expose any part of your body to the vacuum.

Open housing parts with notice sticker (see fig. 1) only after separating mains plug from power source.

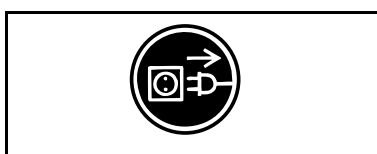

Fig. 1: Notice sticker

Handling dangerous media

When transferring dangerous media, observe the safety regulations when handling these media.

Handling flammable media

Be aware that the pumps are not designed to be explosion-proof.

Make sure the temperature of the medium is always sufficiently below the ignition temperature of the medium, to avoid ignition or explosion. This also applies for unusual operational situations.

Note that the temperature of the medium increases when the pump compresses the medium.

Hence, make sure the temperature of the medium is sufficiently below the ignition temperature of the medium, even when it is compressed to the maximum permissible operating pressure of the pump. The maximum permissible operating pressure of the pump is stated in the technical specifications (see chapter 4).

If necessary, consider any external sources of energy, such as radiation, that may add heat to the medium.

In case of doubt, consult the KNF customer service.

Environmental protection

Store all replacement parts in a protected manner and dispose of them properly in accordance with the applicable environmental protection regulations. Observe the respective national and international regulations. This especially applies to parts contaminated with toxic substances.

Standards	<p>The pumps conform to the Directive 2011/65/EU (RoHS2).</p> <p>The pumps conform to the safety regulations of the EC Directive 2004/108/EC concerning Electromagnetic Compatibility and the EC Directive 2006/42/EC concerning Machinery.</p> <p>The following harmonized standards have been used:</p> <ul style="list-style-type: none">▪ DIN EN 61010-1▪ DIN EN 61000-3-2/3▪ DIN EN 55014-1/2 <p>The pumps correspond to IEC 664:</p> <ul style="list-style-type: none">▪ the overvoltage category II▪ the pollution degree 2
Customer service and repairs	<p>Only have repairs to the pump carried out by the KNF Customer Service responsible.</p> <p>Only authorized personnel should open those parts of the housing that contain live electrical parts.</p> <p>Use only genuine parts from KNF for servicing work.</p>

4. Technical Data

i All pumps are secured against overheating with thermal switches and are equipped with a mains fuse.

Pump materials

N 938.50 KN.18

Component	Pump material
Pump head	PPS
Diaphragm	EPDM
Valves	EPDM
O-rings	FPM

Tab. 2

N 938.50 KT.18

Component	Pump material
Pump head	PPS
Diaphragm	PTFE-coated
Valves	FFPM
O-rings	FPM

Tab. 3

i Refer to the type plate for the pump's electrical configuration.

N 938.50 KN.18

<i>Pneumatic performance</i>				
Max. permissible operating pressure [bar g]	0.5			
Ultimate vacuum [mbar abs.]	12			
Delivery rate at atm. pressure [l/min]*	32			
<i>Pneumatic connections</i>				
Hose connection [mm]	ID 10			
<i>Ambient and media temperature</i>				
Permissible ambient temperature	+ 5 °C to + 40 °C			
Permissible media temperature	+ 5 °C to + 40 °C			
<i>Other parameters</i>				
Weight [kg]	6.9			
Dimensions: L x H x W [mm]	402 x 212 x 110			
Maximum permissible ambient relative humidity	80 % for temperatures up to 31 °C, decreasing linearly to 50 % at 40 °C			
Max. altitude of site [m above sea level]	2000			
<i>Electrical Data</i>				
Voltage [V]	100	115	220	230
Frequency [Hz]	50/60	60	60	50
Max. operating current [A]	1.6	1.2	0.7	0.6
Power consumption pump [W]	110	110	110	110
Maximum permitted mains voltage fluctuations	+/- 10 %	+/- 10 %	+/- 10 %	+/- 10 %
Fuse pump** (2x) T [A]	4.0	3.15	2.0	1.6
Protection class motor	IP20			

Tab. 4

*Liters in standard state (1,013 mbar)

**For spare part-No. see chapter 10

N 938.50 KT.18

<i>Pneumatic performance</i>				
Max. permissible operating pressure [bar g]	0.5			
Ultimate vacuum [mbar abs.]	15			
Delivery rate at atm. pressure [l/min]*	30			
<i>Pneumatic connections</i>				
Hose connection [mm]	ID 10			
<i>Ambient and media temperature</i>				
Permissible ambient temperature	+ 5 °C to + 40 °C			
Permissible media temperature	+ 5 °C to + 40 °C			
<i>Other parameters</i>				
Weight [kg]	6.9			
Dimensions: L x H x W [mm]	402 x 212 x 110			
Maximum permissible ambient relative humidity	80 % for temperatures up to 31 °C, decreasing linearly to 50 % at 40 °C			
Max. altitude of site [m above sea level]	2000			
<i>Electrical Data</i>				
Voltage [V]	100	115	220	230
Frequency [Hz]	50/60	60	60	50
Max. operating current [A]	1.6	1.2	0.7	0.6
Power consumption pump [W]	110	110	110	110
Maximum permitted mains voltage fluctuations	+/- 10 %	+/- 10 %	+/- 10 %	+/- 10 %
Fuse pump** (2x) T [A]	4.0	3.15	2.0	1.6
Protection class motor	IP20			

Tab. 5

*Liters in standard state (1,013 mbar)

**For spare part-No. see chapter 10

5. Design and Function

Design N 938.50 K_.18

- 1 Inlet (suction side)
- 2 Pump head
- 3 Outlet (pressure side)
- 4 Pneumatic connection
- 5 Power switch

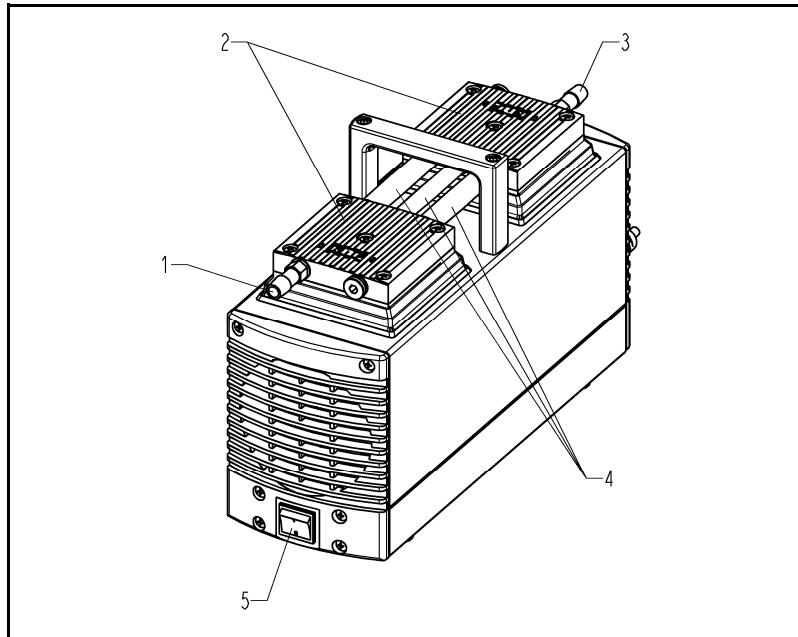

Fig. 2

Function Diaphragm Pump

- 1 Outlet valve
- 2 Inlet valve
- 3 Transfer chamber
- 4 Diaphragm
- 5 Eccentric
- 6 Connecting rod
- 7 Pump drive

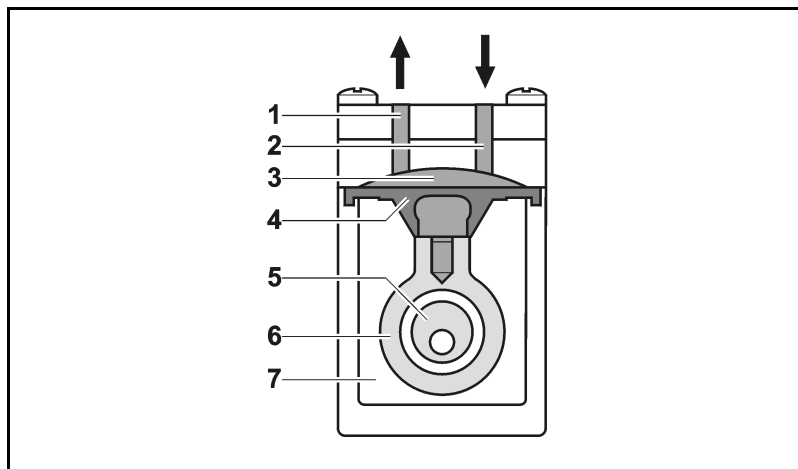

Fig. 3: Pump head

Diaphragm pumps transfer, compress (depending on pump version) and evacuate gases and vapors.

The elastic diaphragm (4) is moved up and down by the eccentric (5) and the connecting rod (6). In the downward stroke it aspirates the gas to be transferred via the inlet valve (2). In the upward stroke, the diaphragm presses the medium out of the pump head via the outlet valve (1). The transfer chamber (3) is hermetically separated from the pump drive (7) by the diaphragm.

6. Installation and connection

Only install and operate the pumps under the operating parameters and conditions described in chapter 4, Technical data.

Observe the safety precautions (see chapter 3).

6.1. Installation

- Before installation, store the pump at the installation location to bring it up to room temperature.
- Dimensions → See chapter 4, Technical data, for the dimensions of pump.
- Cooling air supply → Install the pump so that the motor fan can intake sufficient cooling air.
- Installation location → Make sure that the installation location is dry and the pump is protected against rain, splash, hose and drip water.
- Choose a safe location (flat surface) for the pump.
- Protect the pump from dust.
- Protect the pump from vibrations and jolts.

6.2. Connection

- Connected components → Only connect components to the pump which are designed for the pneumatic data of the pump (see chapter 4).
- Pump exhaust → If the pump is used as a vacuum pump, safely discharge the pump exhaust at the pump's pneumatic outlet.
- Connection
 - i** A marking on the pump head shows the direction of flow.
 - 1. Remove the protective plugs from the pneumatic connectors of the pump.
 - 2. Mount accessory parts filter or silencer (if present).
 - i** Before mounting the filter, unscrew the hose connector from the thread in the pump head.
 - 3. Connect the suction line and pressure line (tube ID 10 mm).
 - 4. Lay the suction and pressure line at a downward angle to prevent condensate from running into the pump.
 - 5. Insert the power cable's plug into a properly installed shockproof socket.

7. Operation

7.1. Preparing for Start-up

Before switching on the pump, observe the following points:

	Operational requirements
Pump	<ul style="list-style-type: none"> ▪ All hoses attached properly ▪ Fan openings not blocked ▪ Specifications of the power supply correspond with the data on the pump's type plate. ▪ The pump outlet is not closed or constricted.

Tab. 6

7.2. Starting

- ➔ Only operate the pump under the operating parameters and conditions described in chapter 4, Technical data.
- ➔ Make sure the pump is used properly (see chapter 2.1).
- ➔ Make sure the pump is not used improperly (see chapter 2.2).
- ➔ Observe the safety precautions (see chapter 3).



WARNING

Hazard of the pump head bursting due to excessive pressure increase

- ➔ Do not exceed max. permissible operating pressure (see chapter 4).
- ➔ Monitor pressure during operation.
- ➔ If the pressure exceeds the maximum permissible operating pressure, immediately shut down pump and eliminate fault (see chapter 9. Troubleshooting).
- ➔ Only throttle or regulate the air or gas quantity in the suction line to prevent the maximum permissible operating pressure from being exceeded.
- ➔ If the air or gas quantity in the pressure line is throttled or regulated, make sure that the maximum permissible operating pressure of the pump is not exceeded.

i Excessive pressure (with all of the related hazards) can be prevented by placing a bypass line with a pressure-relief valve between the pressure and suction side of the pump. For further information, contact your KNF technical adviser.

- Pump standstill ➔ With the pump at a standstill, open pressure and suction lines to normal atmospheric pressure.

**WARNING**

Automatic starting can cause personal injury and pump damage

When the operation of the pump is interrupted by the thermal switch, the pump will restart automatically after cooling down.

- After triggering of the thermal protection or in the event of power failure, remove the pump's mains plug from the socket so that the pump cannot start uncontrollably.
 - Attempt work on the pump only if the pump is separated from mains power.
-

7.3. Switching pump on and off

Switching pump on

i The pump may not start up against pressure or suction during switch-on. This also applies in operation following a brief power failure. If a pump starts against pressure or vacuum, it may block. This activates the thermal switch, and the pump switches off.

- Make sure that no vacuum or pressure is present in the lines during switch-on.
- Switch on pump with mains switch (see fig. 2).

Switching off the pump/removing from operation

- When transferring aggressive media, flush the pump prior to switch-off to increase the service life of the diaphragm (see chapter 8.2.1).
- Switch off pump with mains switch (see fig. 2).
- Open pressure and suction lines to normal atmospheric pressure.
- Disconnect the power source.

8. Servicing

8.1. Servicing Schedule

Component	Servicing interval
Pump	Regular inspection for external damage or leaks
Filter (Accessory)	Replace if it is dirty
Diaphragm and valve plates	Replace at the latest, when pump output decreases

Tab. 7

8.2. Cleaning

i When cleaning, make sure that no liquids enter the inside of the housing.

8.2.1. Flushing Pump

→ Before switching off the pump, flush it with air (if necessary for safety reasons: with an inert gas) for about five minutes under atmospheric conditions (ambient pressure).

8.2.2. Cleaning Pump

- As far as possible, clean the parts with a dry cloth.
- Only use solvents for cleaning if the head materials cannot be attacked (check the resistance of the material!).
- If compressed air is available, blow out the components.

8.3. Changing Diaphragm and Valves

Conditions

- Pump is switched off and mains plug is removed from the socket
- Pump is clean and free of hazardous materials
- Tubes removed from pump's pneumatic inlet and outlet

Spare parts/tools

Spare parts/tools
Service Set (according to chapter 10)
Philips-head screwdriver No. 2
Small screwdriver (blade width 0.5 mm)
Pencil

Tab. 8

Information on procedure

- ➔ Always replace diaphragm and valve plates together to maintain the pump performance.
- ➔ Replace the diaphragms and valve plates of the pump heads consecutively.



WARNING

Health hazard due to dangerous substances in the pump!

Depending on the substance transferred, caustic burns or poisoning are possible.

- ➔ Wear protective clothing if necessary, e.g. protective gloves.
- ➔ Flush pump before replacing the diaphragm and valve plates (see chapter 8.2.1).

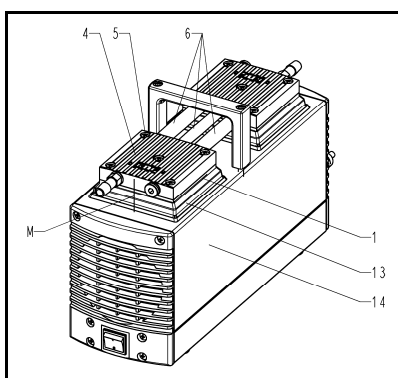

Fig. 4: Remove pump heads

Remove pump heads

1. At both pump heads: Mark the position of head plate (4), intermediate plate (1), cover (13) and housing (14) relative to each other by a drawing line (M) with a pencil. This helps avoid incorrect assembly later.
2. At both pump heads: Undo the 4 screws (5) in the head plate (4).
3. Removing the pump heads:
 - i** To remove the pump heads from the housing (14), first remove the connection between the two pump heads:
 - Lift the pump heads slightly.
 - Pull the connection tubes (6) from one of the two pump heads.
 - Remove the pump heads (consisting of head plate (4) and intermediate plate (1)) from the housing (14).

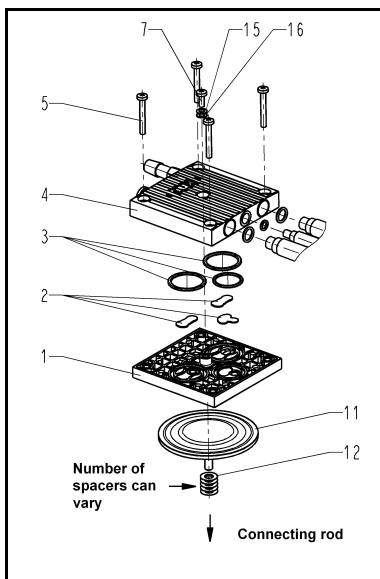

Fig. 5: Pump head (Exploded drawing)

Change diaphragm

i Replace the diaphragms consecutively to ensure that the same number of diaphragm spacers is used as before.

1. Push down one diaphragm (**11**) to bring the other diaphragm to top dead centre.
2. Lift the edge of the highest diaphragm (**11**) and, gripping it on opposite sides, unscrew it by turning anti-clockwise.

i Make sure the diaphragm spacers (**12**) on the thread of the diaphragm (**11**) do not fall into the pump housing.

3. Take the diaphragm spacers (**12**) off the threaded portion of the diaphragm (**11**) and retain them.
4. Check that all parts are free from dirt and clean them if necessary (see chapter 6. Cleaning).
5. Put the diaphragm spacers (**12**) on the thread of the new diaphragm (**11**).
6. Push down the diaphragm (**11**) of the second pump head until the connecting rod (connecting part between motor shaft and diaphragm) is at top dead centre.
7. Screw the new diaphragm (**11**), complete with diaphragm spacers (**12**), into the connecting rod (clockwise) and tighten it by hand.
8. Carry out steps 1 to 7 for the second pump head.

Changing the valve plates

1. For one pump head: Undo the screw (**7**).
2. Separate the head plate (**4**) from intermediate plate (**1**).
3. Remove the valve plates/sealings (**2**) from the intermediate plate (**1**).
4. Check that the valve seats, intermediate plate (**1**) and the head plate (**4**) are clean; if scratches or distortion are evident on these parts they should be replaced.
5. Lay the new valve plates/sealings (**2**) in the recesses in the intermediate plate (**1**). The valve plates/sealings for suction and pressure sides are identical, as are upper and lower sides of the valve plates/sealings.
6. Check that the valve plates/sealings (**2**) are not deformed by moving them gently sideways in their recesses.
7. Place the head plate (**4**) on the intermediate plate (**1**), in the position indicated by the marking (**M**).
8. Check that the head plate (**4**) is centred by moving it gently sideways.
9. Join the head plate (**4**) and the intermediate plate (**1**): Tighten the screw (**7**) (tightening torque: 70 Ncm).

i For placement of disk spring (**15**) and washer (**16**) and for orientation of disk spring see fig. 6.

10. Carry out steps 1 to 10 for the second pump head.

11. Dispose of the old diaphragms and valve plates/sealings properly.

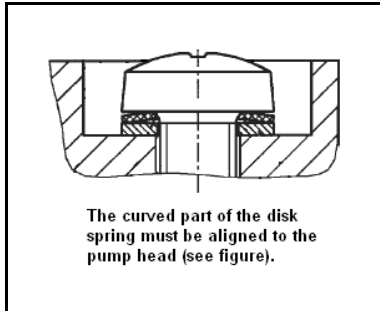

Fig. 6: Orientation disk spring

Refit pump heads

1. Refit the pump heads as follows:

- i** When refitting the pump heads, make sure that their connection tubes run underneath the carrying handle:
- Position the pump head with the connection tubes (Fig. 4/6) so that the connection tubes are underneath the carrying handle (Observe mark **(M)**).
 - Reinsert connection tubes (**6**) into the second pump head.
 - Place the pump heads, together with the connection tubes, onto the housing (**14**).

i Make sure the cover (fig. 12/13) is placed on the pump head and is not jammed. For this, carefully slide a small screw driver between the cover (**13**) and the pump head.

i If the cover is jammed between the intermediate plate (**1**) and head plate (**4**), then the pump will not provide the nominal pneumatical performance.

2. On both pump heads: Gently tighten the screws (**5**), evenly and diagonally (tightening torque: 3 Nm)

Final steps

1. Reconnect suction and pressure line to the pump.
2. Reconnect the pump to the electricity supply.

If you have any question about servicing call your KNF technical adviser (see last page for contact telephone number).

9. Troubleshooting



Extreme danger from electrical shock!

→ Disconnect the pump power supply before working on the pump.

DANGER

→ Make sure the pump is de-energized and secure.

→ Check the pump (see Tab. 9 to 12).

Pump produces no flow	
Cause	Fault remedy
No voltage in the power source	→ Check room fuse and switch on if necessary.
Thermal switch has operated following to over-heating.	→ Disconnect pump from mains. → Allow pump to cool. → Trace cause of over-heating and eliminate it.
Connections or lines blocked.	→ Check connections and lines. → Remove blockage.
External valve is closed or filter is clogged.	→ Check external valves and filters.
Condensate has collected in pump head.	→ Detach the condensate source from the pump. → Flush pump (see chapter 8.2.1).
Diaphragm or valve plates/sealings are worn.	→ Replace diaphragm and valve plates/sealings (see chapter 8.3).

Tab. 9

Flow rate, pressure or vacuum too low	
The pump does not achieve the output specified in the Technical data or the data sheet.	
Cause	Fault remedy
Condensate has collected in pump head.	→ Detach the condensate source from the pump. → Flush pump (see chapter 8.2.1).
There is gauge pressure on pressure side and at the same time vacuum or a pressure above atmospheric pressure on suction side.	→ Change the pressure conditions.
Pneumatic lines or connection parts have an insufficient cross section.	→ Disconnect pump from system to determine output values. → Eliminate throttling (e.g. valve) if necessary. → Use lines or connection parts with larger cross section if necessary.
Leaks occur on connections, lines or pump head.	→ Check that tubes sit correctly on hose nozzles. → Replace leaky tubes. → Eliminate leaks.
Connections or lines completely or partially jammed.	→ Check connections and lines. → Remove the jamming parts and particles.
Head parts are soiled.	→ Clean head components.
Diaphragm or valve plates/sealings are worn.	→ Replace diaphragm and valve plates/sealings, (see chapter 8.3).

Flow rate, pressure or vacuum too low	
The pump does not achieve the output specified in the Technical data or the data sheet.	
Cause	Fault remedy
After diaphragm and valve plates/sealings have been replaced	<ul style="list-style-type: none"> ➔ Check that the spacers have been replaced onto the diaphragm screw thread. ➔ Check head connection and hose connections for leaks. ➔ Possibly carefully tighten the outer screws of the top plate crosswise.

Tab. 10

Pump is switched on, but does not run, the on/off-switch on the pump is not lit	
Cause	Fault remedy
Pump is not connected with the power source.	➔ Connect pump to mains power.
No voltage in the power source	➔ Check room fuse and switch on if necessary.
Fuse in the pump is defective.	<ul style="list-style-type: none"> ➔ Remove pump's mains plug from the socket. ➔ Fuses are located in the housing, and can be accessed by removing the terminal box plate on the bottom of the pump. ➔ Select and replace suitable fuse (see chapter 4).

Tab. 11

Pump is switched on, but does not run, the on/off-switch on the pump is lit	
Cause	Fault remedy
The thermal switch has opened due to overheating	<ul style="list-style-type: none"> ➔ Remove pump's mains plug from the socket. ➔ Allow pump to cool. ➔ Trace cause of over-heating and eliminate it.

Tab. 12

Fault cannot be rectified

If you are unable to determine any of the specified causes, send the pump to KNF Customer Service (see last page for the address).

1. Flush the pump to free the pump head of dangerous or aggressive gases (see chapter 8.2.1).
2. Clean the pump (see chapter 8.2.2).
3. Send the pump, together with completed Health and Safety Clearance and Decontamination Form (Chapter 12), to KNF stating the nature of the transferred medium.

10. Spare parts and accessories

10.1. Spare parts

A Service Set contains all spare parts needed for one complete service

- 2 diaphragms
- 6 valve plates
- 6 O-rings

Service Set for pump type:	Order-No.:
N 938.50 KN.18	124808
N 938.50 KT.18	124809

Tab. 13

Fuses

Each pump contains two fuses.

Pump range	Order-No. fuse (1 piece)
N 938.50 K_.18, 230 V	020255
N 938.50 K_.18, 115 V	020085
N 938.50 K_.18, 100 V	028701
N 938.50 K_.18, 220 V	016767

Tab. 14

10.2. Accessories

Description	Order-No.:
Silencer	007006
Hose connector PVDF	112004
Fine-adjustment valve	112432

Tab. 15

11. Returns

Pumps and systems used in laboratories and process-based industries are exposed to a wide variety of conditions. This means that the components contacting pumped media could become contaminated by toxic, radioactive, or otherwise hazardous substances.

For this reason, customers who send any pumps or systems back to KNF must submit a Health and safety clearance and decontamination form in order to avoid a hazardous situation for KNF employees. This Health and safety clearance and decontamination form provides the following information, among other things:

- physiological safety
- whether medium-contacting parts have been cleaned
- whether the equipment has been decontaminated
- media that have been pumped or used

and must declare physiological safety. To ensure worker safety, work may not be started on pumps or systems without a signed Health and safety clearance and decontamination form.

For optimal processing of a return, a copy of this declaration should be sent in advance via e-mail, regular mail, or fax to KNF Customer Service (refer to final page for address). In order to avoid endangering employees who open the shipment's packaging, despite any residual hazards, the original version of the Health and safety clearance and decontamination form must accompany the delivery receipt on the outside of the packing.

The template for the Health and safety clearance and decontamination form is included with these Operating Instructions and may also be downloaded from the KNF website.

The customer must specify the device type(s) and serial number(s) in the Health and safety clearance and decontamination form in order to provide for the unambiguous assignment of the Declaration to the device that is sent to KNF.

In addition to the customer's declaration of physiological safety, information about operating conditions and the customer's application are also of importance to ensure that the return shipment is handled appropriately. Therefore, the Health and safety clearance and decontamination form requests this information as well.

12. Health and safety clearance and decontamination form



Form: Rev. 00 / download: www.knf.com

Health and safety clearance and decontamination form

This declaration must be present and complete (the original must accompany the shipment's delivery receipt) before the returned device can be examined.

Device type:

Serial number(s):

Reason for returning the device (please describe in detail):

(The device(s) was(were) in operation yes no)

We confirm that the above device(s)

has(have) pumped exclusively **physiologically unobjectionable** media and that it(they) are free of hazardous materials and any materials that are harmful to health.

The device(s) was(were) cleaned yes no

has(have) pumped media of the following category(categories) which are not physiologically unobjectionable and that cleaning of the device(s) (potentially only media-contacting parts) is required.

Name, chemical formula, Material Safety Data Sheet

aggressive

biological

radioactive

toxic

other

The device(s) was(were) decontaminated and work can proceed without special measures yes

Method / proof:

The device(s) was(were) not decontaminated and special measures are required before starting work yes

Measures:

Legally binding declaration

We herewith affirm that the information provided in this form is correct and complete. Shipment of the devices and components is in compliance with statutory regulations.

.....
Company (stamp)

.....
Date

.....
Name

.....
Authorized signature

.....
Position

KNF worldwide

Benelux

Netherlands
KNF Verder B.V.
Utrechtseweg 4a
NL-3451 GG Vleuten
Tel. 0031 (0)30 677 92 40
Fax 0031 (0)30 677 92 47
E-mail: info@knf-verder.nl
www.knf-verder.nl

Benelux

Belgium, Luxembourg
KNF Verder N.V.
Kontichsesteenweg 17
B-2630 Aartselaar
Tel. 0032 (0)3 8719624
Fax 0032 (0)3 8719628
E-mail: info@knf.be
www.knf.be

China

KNF Neuberger Trading
(Shanghai) Co., Ltd
No. 36 Lane 1000
Zhang Heng Road
Shanghai 201203, P.R. China
Tel. 0086 (0)21 685 965 66
Fax 0086 (0)21 339 006 26
E-mail: info@knf.com.cn
www.knf.com.cn

Germany

KNF Neuberger GmbH
Alter Weg 3
D-79112 Freiburg
Tel. 0049 (0)7664 5909-0
Fax 0049 (0)7664 5909-99
E-mail: info@knf.de
www.knf.de

France, Morocco, Algeria

KNF Neuberger SAS
4, Bld. d'Alsace Z.I.
F-68128 Village-Neuf
Tel. 0033 (0)389 70 35 00
Fax 0033 (0)389 69 92 52
E-mail: info@knf.fr
www.knf.fr

Great Britain

KNF Neuberger U.K. Ltd.
Avenue 2
Station Lane
Industrial Estate
Witney Oxon OX28 4FA
Tel. 0044 (0)1993 77 83 73
Fax 0044 (0)1993 77 51 48
E-mail: info@knf.co.uk
www.knf.co.uk

India

KNF Pumps + Systems
(India) Pvt. Ltd.
RAJIV GANDHI INFOTECH
PARK
Phase 1
Ganga Estate, Survey No. 152/2/2
Above AXIS BANK
Hinjewadi
Pune 411 057
Tel. 0091 (0)20 640 13 923
0091 (0)20 640 08 923
Fax 0091 (0)20 229 33 923
E-mail: info@knfpumps.in
www.knfpumps.in

Italy

KNF ITALIA S.r.l.
Via Flumendosa, 10
I-20132 Milano
Tel. 0039 02 27 20 38 60
Fax 0039 02 27 20 38 48
E-mail: info@knf.it
www.knf.it

Japan

KNF Japan Co.Ltd.
Across Shinkawa Bldg. Annex 3F
1-16-14 Shinkawa, Chuo-ku,
Tokyo, Japan 104-0033
Tel. 0081 (0)3 3551-7931
Fax 0081 (0)3 3551-7932
E-mail: info@knf.co.jp
www.knf.co.jp

Korea

KNF Neuberger Ltd.
Woosan Bldg. RM#202,
336-4, Hwikyung-Dong
Dongdaemun-Ku.,
130-090, Seoul
Tel. 0082 (0)2 959-0255/6
Fax 0082 (0)2 959-0254
E-mail: knf@knfkorea.com
www.knfkorea.com

Sweden, Denmark, Finland, Norway

KNF Neuberger AB
Mejerivägen 4,
P.O. Box 44060
SE-10073 Stockholm
Tel. 0046 (0) 87445113
Fax 0046 (0) 87445117
E-mail: info@knf.se
www.knf.se

Switzerland

Sales
KNF Neuberger AG
Stockenstrasse 6
CH-8362 Balterswil
Tel. 0041 (0)71 973 993 0
Fax 0041 (0)71 973 993 1
E-mail: knf@knf.ch
www.knf.ch

Taiwan

KNF Neuberger Ltd.
9-2 FL., No., 24, Lane 123,
Section 6,
Ming Chuan East Road
Taipei City, Taiwan
Tel. 00886-2-2794-1011
Fax 00886-2-8792-1648
E-mail: knftwn@knftwn.com.tw
www.knftwn.com.tw

USA, Canada, South America

KNF Neuberger, Inc.
Two Black Forest Road
Trenton, New Jersey
08691-1810
Tel. 001 (609) 890-8600
Fax 001 (609) 890-8323
E-mail: knfusa@knf.com
www.knfusa.com
South America
Direct Phone: 001 609-649-
1010
E-mail: qb@knf.com

KNF product centres

Product centre for gas pumps:

Germany
KNF Neuberger GmbH
Alter Weg 3
D-79112 Freiburg
Phone 0049(0)7664 5909-0
Fax 0049(0)7664 5909-99
E-mail: info@knf.de
www.knf.de

Product centre for fluid pumps:

Switzerland
KNF FLODOS AG
Wassermatte 2
CH-6210 Sursee
Phone 0041(0)41 925 00 25
Fax 0041(0)41 925 00 35
E-mail: info@knf-flodos.ch
www.knf-flodos.ch

Product centre for micro pumps:

Switzerland
KNF Micro AG
Zelglimatte 1b
CH-6260 Reiden
Tel. 0041(0)62 787 88 88
Fax 0041(0)62 787 88 99
E-mail: info@knf-micro.ch
www.knf-micro.ch